

SHARP

MX-3114N / MX-2614N
Digital Full Colour Multifunctional System

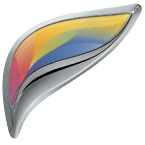

**COMPACT YET POWERFUL
A3 COLOUR MFP**

**You need performance. You care about the environment.
/This is Why Sharp MFPs are the smart choice.**

Great colour shouldn't require a compromise /This is Why we put performance first.

Here's the problem. You want an A3 colour MFP which is not only powerful but easy to use. And, naturally, it should have impeccable green credentials. Easy.

You'll find all this and more with the next-generation MX-2614N and MX-3114N.

They deliver stunning A3 colour output, they're loaded with the latest productivity features – including access to the 'cloud'* and driverless mobile printing - and they're still a great choice for colour that's kinder to the environment.

First choice for fast A3 colour

The 26 pages per minute (ppm) MX-2614N and the 31 ppm MX-3114N have everything you're looking for.

You get full speed network printing and copying, automatic two-sided colour scanning, a 320GB internal hard drive, robust security (including access control, data encryption and secure erasure), Sharpdesk desktop scanning software, and powerful device management tools.

You can also add a retractable keyboard for easy data entry and emailing, a Wi-Fi adaptor, a space-saving inner finisher, a hole punch, integrated fax capability and - thanks to Sharp OSA – a range of useful software solutions.

Plus you can control every function from a 7.0" colour touch screen, which also gives you thumbnail previews of your saved documents.



PRODUCTIVE A3 COLOUR

*Available at a later date.

SPACE-SAVING INNER FINISHER

All the right connections

These latest models let you reach out to do so much more than 'ordinary' MFPs. Their hard drives can be used as Network-attached Storage (NAS) devices, for instance, making it easy to share files and collaborate with colleagues.

We also offer 'cloud' connectivity options and the ability to run Software as a Service (SaaS)* applications, such as those developed by our technology partners.

There's even more good news for smartphone or tablet PC owners. Our free Sharpdesk Mobile App lets them wirelessly print, scan and share files without any extra drivers or manual setup processes.



Plenty of paper capacity

Big paper supplies let everyone keep printing more, for longer. So you'll be pleased to know that the MX-2614N and MX-3114N's standard paper capacity of 600 sheets can grow right the way up to 3,100 sheets (choose the Large Capacity Tandem Drawers for long uninterrupted print runs) and with the long paper feeding tray and media, you can also print eye-catching banners.

Additional security

If your team routinely handles sensitive information it's a good idea to add our optional Data Security Kit too, which can prevent the unauthorised copying, scanning, faxing or filing of sensitive documents, keeping everything safely under your control.

USB WIRELESS LAN ADAPTOR



*Available at a later date.

We all have to share the same planet /This is Why we're making our products greener.

These Energy Star-certified MFPs have a Typical Electrical Consumption among the lowest in their class.

We've put LED lights in the scanner to use less power. The warm up time is 18 seconds. In standby mode, power consumption is just enough to receive a fax. They will even 'learn' your usage patterns and automatically move into a user-adjustable standby mode during periods of inactivity. Very few MFPs are as green as these.

Energy-saving scanning

An Eco Scan feature keeps the fuser turned off until it's needed, delivering significant savings.

If you don't need hard copy, you can scan originals directly into most popular formats then instantly send them to your desktop, multiple email addresses, a folder on your network, FTP server, or a USB memory stick.



Effortless management and support

The MX-2614N and MX-3114N are truly easy to manage. Every important setting can be configured from a dedicated web page.

A **Printer Status Monitor** on your PC lets you check that there's enough toner and paper before you start a job. A glance at the Job Status Screen will reveal every copy and print job and its position in the queue. And an alert will pop up as soon as your documents are printed.

Your support staff will love them, too.

A **Remote Diagnosis** feature lets them monitor your MFPs through a web browser, and they'll get timely email messages when maintenance is required.

Sharp Remote Device Manager also gives them real-time control of your Sharp MFPs - again, through a browser - making technical support, driver installation and firmware upgrades easier than ever.

They can even remotely view* and operate the front panel display, taking control, changing settings, fixing problems and providing ad hoc training, without ever leaving their desks, thanks to our innovative Remote Access Control Panel.



REMOTE ACCESS
CONTROL PANEL

*Requires VNC application.

OPTIONS & CONFIGURATION EXAMPLES

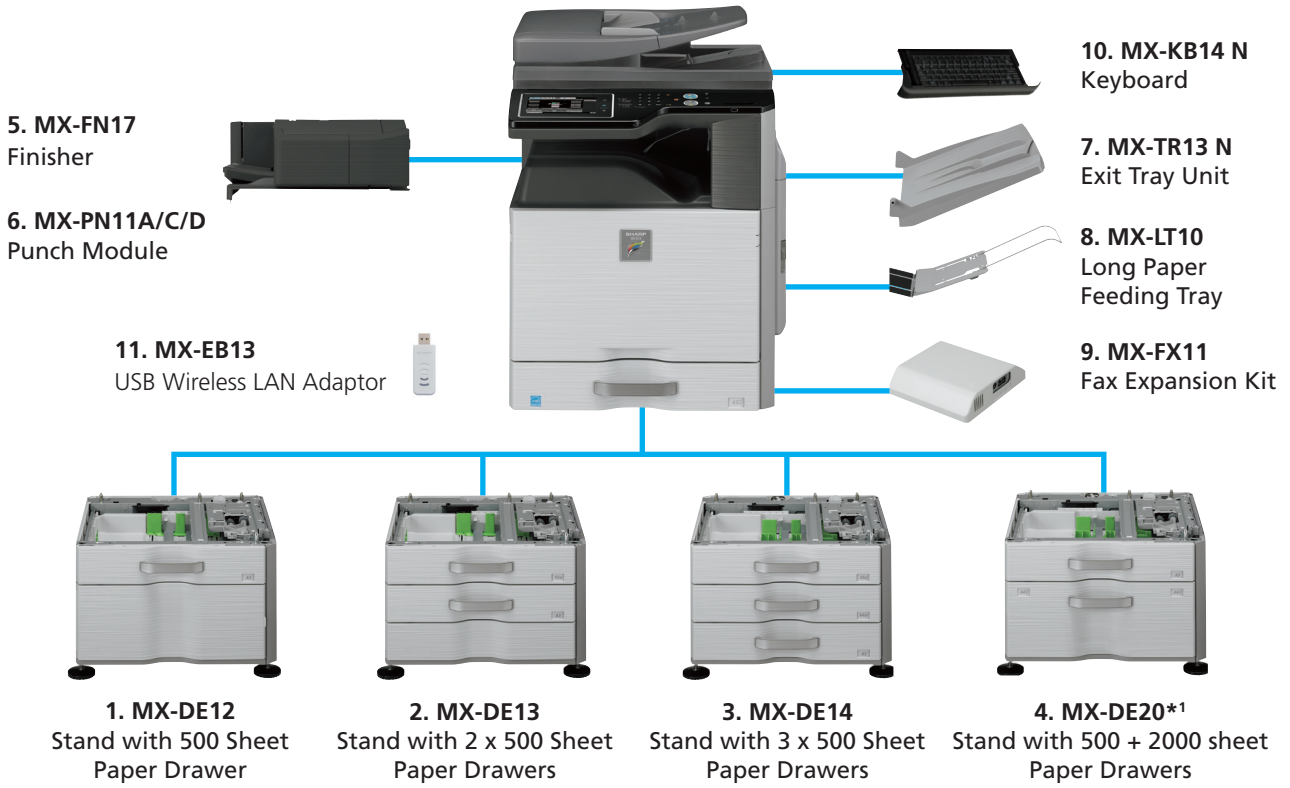

*1 Available at a later date



Base Unit
Exit Tray Unit
Stand with 3 x 500 Sheet Paper Drawers



Base Unit
Exit Tray Unit
Inner Finisher
Stand with 3 x 500 Sheet Paper Drawers



Base Unit
Exit Tray Unit
Inner Finisher
Stand with 500 + 2000 Sheet Paper Drawers

Base Unit

1. MX-DE12 Stand with 500 Sheet Paper Drawer

A5R - A3, 500 sheets, (80 g/m²)

2. MX-DE13 Stand with 2 x 500 Sheet Paper Drawers

Upper/Lower tray: A5R - A3, 500 sheets each (80 g/m²)

3. MX-DE14 Stand with 3 x 500 Sheet Paper Drawers

Upper/Middle/Lower tray: A5R - A3, 500 sheets each (80 g/m²)

4. MX-DE20*1 Stand with 500 + 2000 Sheet Paper Drawers

Upper tray: A5R - A3, 500 sheets (80 g/m²)

Lower tray: A4, 1 x 1150 sheets, 1 x 850 sheets, (80 g/m²)

Finishing

5. MX-FN17 Finisher

A3 to B5 (offset/staple),

A3W to A5R (non offset)

Offset tray (upper): max. 500-sheet paper capacity*2

Stapling capacity: max. 50-sheet multi-position staple*2

Staple position: 3 locations (front, rear or 2 point stitching)

6. Optional Punch Module for MX-FN17

MX-PN11A - 2 Hole Punch Module

MX-PN11C - 4 Hole Punch Module

MX-PN11D - 4 Hole Wide Punch Module

7. MX-TR13 N Exit Tray Unit

8. MX-LT10 Long Paper Feeding Tray

Faxing

9. MX-FX11 Fax Expansion Kit

Super G3 fax module

MX-FWX1 Internet Fax Expansion Kit

Connectivity

10. MX-KB14 N Keyboard

11. MX-EB13 USB Wireless LAN Adaptor

Enables connection to wireless networks

Printing

MX-PF10 Barcode Font Kit

Enables barcode printing

MX-PK11 PS3 Expansion Kit

Enables PostScript printing

MX-PUX1 XPS Expansion Kit

Enables XPS printing

(XPS printing requires 2GB of additional memory)

Scanning

AR-SU1 Stamp Unit

Marks already scanned documents for checking

Sharpdesk™ Licenses

MX-USX1/X5/10/50/A0

1/5/10/50/100-License Kit

Sharp OSA®

MX-AMX1 Application Integration Module

MX-AMX2 Application Communication Module

MX-AMX3 External Account Module

Security

MX-FR40U*1 Data Security Kit

*1 Available at a later date **2 A4 or smaller, 80g/m². Some options may not be available in some areas.

GENERAL

Engine speed (ppm/cpm) (Max)	A4	A3
MX-2614N	26	14
Colour	26	14
B&W	26	14
MX-3114N	31	15
Colour	31	15
B&W	31	15

Paper size (Min – Max)	A5R – A3W
Drawers	A5R – A3W
Multi bypass	1,200 x 320 mm (Max)

Paper weight (g/m²)	60 – 209
Drawer	60 – 209
Multi bypass	55 – 256

Paper capacity (Std – Max)	600 – 3,100
Sheets	600 – 3,100
Drawers	1 – 4 (plus bypass tray)

Warm-up time*1 (seconds)	18
---------------------------------	----

Memory (GB)	3
Standard: Copier/Printer (shared)	3
Option: Printer	2*2
Standard: HDD*3	320

Power requirements	Rated local AC voltage $\pm 10\%$, 50/60 Hz
---------------------------	--

Power consumption (kW) (Max)	1.84 (220 - 240V)
-------------------------------------	-------------------

Dimensions (mm) (W x D x H)	608 x 642 x 834
------------------------------------	-----------------

Weight (kg)	76.2
--------------------	------

COPIER

Original paper size (Max)	A3
----------------------------------	----

First copy time** (seconds)	Full Colour	B/W
MX-2614N	8.1	5.9
MX-3114N	7.9	5.8

Continuous copies (Max)	999
--------------------------------	-----

Resolution (dpi)	600 x 600
Scan (colour)	600 x 600, 600 x 400, 600 x 300
Scan (b/w)	600 x 600, 9600 equivalent*5 x 600
Print	(depending on print mode)

Gradation levels	256
-------------------------	-----

Zoom range (%)	25 – 400 (25 – 200 using RSPF) in 1% increments
-----------------------	---

Preset copy ratios	10 (SR/5E)
---------------------------	------------

NETWORK PRINTER

Resolution (dpi)	600 x 600, 9600 equivalent*5 x 600
-------------------------	------------------------------------

Interface	USB 2.0 10Base-T/100Base-TX/1000Base-T
------------------	---

Supported OS	Std Windows® XP, Windows Server® 2003/2008/2008R2, Windows Vista®, Windows® 7
Opt*6	Mac OS X, 10.4.11, 10.5 - 10.5.8, 10.6 - 10.6.8, 10.7 - 10.7.4

Network protocols*6	TCP/IP (IPv4, IPv6), IPX/SPX (NetWare), EtherTalk (AppleTalk)
----------------------------	---

Printing protocols	LPR, Raw TCP (port 9100), POP3 (e-mail printing), HTTP, Novell Printserver application with NDS and Bindery, FTP for downloading print files, EtherTalk printing, IPP
---------------------------	---

PDL emulation	Std PCL 6
Opt*7	PS3, XPS

Available fonts	PCL 80
PS3*6	136

EXTERNAL DIMENSIONS

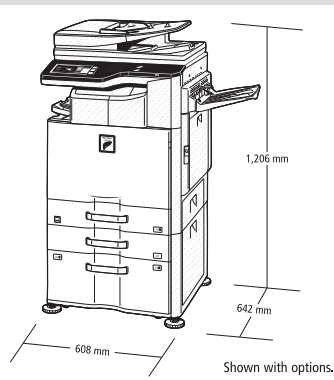

NOTES

Design and specifications are subject to change without prior notice. All information was correct at time of print. The ENERGY STAR logo is a certification mark and may only be used to certify specific products that have been determined to meet the ENERGY STAR programme requirements. ENERGY STAR is a US registered mark. The ENERGY STAR guidelines apply to products only in the US, Europe, Australia, New Zealand and Japan. Windows, Windows XP and Windows Vista are registered trade marks of Microsoft Corporation. All other company names, product names and logotypes are trademarks or registered trademarks of their respective owners. ©Sharp Corporation December 2014 Ref: MX-2614N/3114N. All trademarks acknowledged. E&OE. UK. December 2014

DOCUMENT FILING

Document filing capacity	(pages / or files)
Main and custom folders	20,000*8 or 3,000
Quick file folder	10,000*8 or 1,000

Stored jobs	Copy, print, scan, fax transmission*9
--------------------	---------------------------------------

Storage folders	Quick file folder, main folder, custom folder (max. 1,000 folders)
------------------------	--

Confidential storage	Password protection
-----------------------------	---------------------

NETWORK SCANNER

Scan method	Push scan (via operation panel) Pull scan (TWAIN-compliant application)
--------------------	--

Resolution (dpi)	100, 200, 300, 400, 600
Push scan	75, 100, 150, 200, 300, 400, 600
Pull scan	50 - 9600*5 via user setting

File formats	TIFF, PDF, PDF/A-1b, encrypted PDF, JPEG (colour only), XPS*10
---------------------	--

Scan destinations	Scan to e-mail, desktop, FTP server, network folder (SMB), USB memory
--------------------------	---

Scanner utilities	Sharp OSA Network Scanner Tool, Sharpdesk, Sharpdesk Mobile
--------------------------	---

FAX (requires optional MX-FX11)

Compression method	MH/MR/MMR/JBIG
---------------------------	----------------

Communication protocol	Super G3/G3
-------------------------------	-------------

Transmission time*11 (seconds)	Less than 3
---------------------------------------	-------------

Modem speed (bps)	33,600 – 2,400 with automatic fallback
--------------------------	--

Transmission resolution (dpi)	Std 203.2 x 97.8
Ultra Fine	406.4 x 391

Recording width	A5 - A3
------------------------	---------

Memory (GB)	1
--------------------	---

Grey scale levels	256
--------------------------	-----

*1 At rated voltage. May vary depending on machine conditions and operating environment.

*2 Required if adding MX-PUX1 for XPS printing

*3 1GB = One billion bytes when referring to hard drive capacity. Actual formatted capacity is less.

*4 Best achieved time based on A4 copy, long-edge feeding from 1st paper drawer, using document glass, when machine is ready, without Auto Colour Mode and Auto Colour Selection. May vary depending on machine conditions and operating environment.

*5 Resolutions higher than 600 dpi are interpolated.

*6 Optional MX-PK11 required for Mac OS, EtherTalk and PS3.

*7 PS requires optional MX-PK11. XPS requires optional MX-PUX1 and additional 2 GB memory.

*8 Measured using Sharp's standard chart (A4 with 6% coverage, B/W). The Quick Folder shares memory with the Job Build function; The storage capacity will be less for colour pages.

*9 Optional MX-FX11 required.

*10 To view XPS files on PCs not running Windows Vista, you must have the XPS View application installed.

*11 Based on Sharp's standard chart with approx. 700 characters (A4 portrait) at standard resolution in Super G3 mode, 33,600 bps, JBIG compression.

This is Why

www.sharpbusiness.com

SHARP

DEALER STAMP

SHARP BUSINESS SYSTEMS UK PLC
NORTHERN HOUSE, MOOR KNOLL LANE,
EAST ARDSLEY, WAKEFIELD WF3 2EE
E: enquiries@sharpbusiness.com
W: sharpbusiness.com
T: 01924 823455

